

Water Heaters



- Fused Ceramic Shield™ tank lining is corrosion-resistant for years of dependability.
- Adjustable temperature controls for "set and forget" comfort and convenience.
- Non-CFC foam insulation traps heat inside the tank, saving energy
- Anode rod gives added protection against corrosion
- Heavy-duty burner assembly for even flame distribution, powerful heating and quick recovery. Propane models feature rugged cast-iron burner.
- Unique flue baffle extracts heat for maximum efficiency.



One Year Warranty								
ELECTRIC								
Stock #	U.S. GAL.	# of Elements	Volts	Weight	CONN. INS.	Height Inches	Dia.	Watts
431705	30	2	240	79	Side	45-1/4"	18"	4500
431707	30	2	240	91	Top	29-1/2"	22"	4500
431739	30	2	240	91	Side	29-1/2"	22"	4500
431709	30	1	120	91	Top	29-1/2"	22"	1500
431738	30	1	120	91	Side	29-1/2"	22"	1500
431716	40	2	240	122	Top	31-5/8"	24"	4500
431712	40	2	240	94	Top	47-1/4"	20"	4500
431714	40	2	240	94	Side	47-1/4"	20"	4500
431711	40	2	240	94	Side	47-1/4"	20"	3500
431718	50	2	240	115	Top	50"	20"	4500
NATURAL GAS*								
431720	30	3" VENT		107	Top/Top	59-3/4"	16	31,000
431722	40	3" VENT		123	Top/Top	60-3/4"	18	31,000
Five Year Warranty								
								BTU
PROPANE GAS SEALED COMBUSTION DIRECT VENT*								
431725	30	n/a	n/a	103	Side/Top	56-1/4"	16	30,000
431727	40	n/a	n/a	119	Side/Top	56-3/4"	18	30,000

Items in RED are **NEW!**

Six Year Warranty								
ELECTRIC								
Stock #	U.S. GAL.	# of Elements	Volts	Weight	CONN. INS.	Height Inches	Dia.	Watts
431703	20	1	120	60	Side	24-3/4"	18"	1500
431706	30	2	240	79	Side	45-1/4"	18"	4500
431708	30	2	240	91	Top	29-1/2"	22"	4500
431740	30	2	240	91	Side	29-1/2"	22"	4500
431710	30	1	120	91	Top	29-1/2"	22"	1500
431741	30	1	120	91	Side	29-1/2"	22"	1500
431717**	40	2	240	122	Top	31-5/8"	22"	4500
431715	40	2	240	94	Side	47-1/4"	20"	4500
431735	40	2	240	94	Top	47-1/4"	20"	4500
431719	50	2	240	115	Top	50"	20"	4500
NATURAL GAS*								
								BTU
431721	30	3" VENT		107	Top/Top	59-3/4"	16	31,000
431723	40	3" VENT		123	Top/Top	60-3/4"	18	31,000

* Comes equipped for natural; contains kit to convert to propane gas.
 ** Sold with exterior blanket to meet DOE compliance.



Continuity Tester



Tests elements and thermostats while they are in the water heater. LED light indicates continuity. Unbreakable body with protective covers over light and probe.

382006 12/Ctn.

Drip Pan

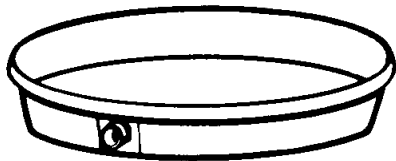

Plastic polymer, semi-flexible. Will not rust or corrode. Pre-drilled to accept furnished 1" PVC plastic fitting. Meets requirement of Southern Building Code.

260155 22"; 12/Ctn.

260156 24"; 12/Ctn.



Electric Thermostat

Replacement for any electric, domestic water heater.

431901 Double-throw 240V; 12/Ctn.

431904 Thermo Disc Single Pole; 12/Ctn.

431906 Lower Thermostat; 25/Ctn.

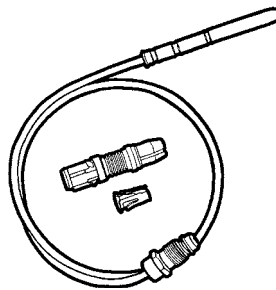

Thermocouple

Fully universal. Fits push-in, screw-in or clamp-on type pilot burners. 24/Ctn.

232501 18"

232502 24"

232503 30"



Water Heater Door

Without Vents

212000 22" x 60"

With Vents

(Not Shown)

432050 22" x 60"

211999 23" x 60"

Water Heater Gas Valve



Convertible gas valve for mobile home heaters. 1-1/2" shank.

430415 Sealed Combustion

430416 Atmospheric

Temperature & Pressure Relief Valve



Temperature and pressure relief valve with test lever, stainless steel spring and all bronze body. Thermostat is positive, accurate and proven. Self-closing. 50/Ctn.

- 430120** 3/4" x 4" L
- 432048** 3/4" x 5" L
- 432046** 1/2" x 4" L

Vent Packages

for Propane Gas Sealed Combustion Water Heaters

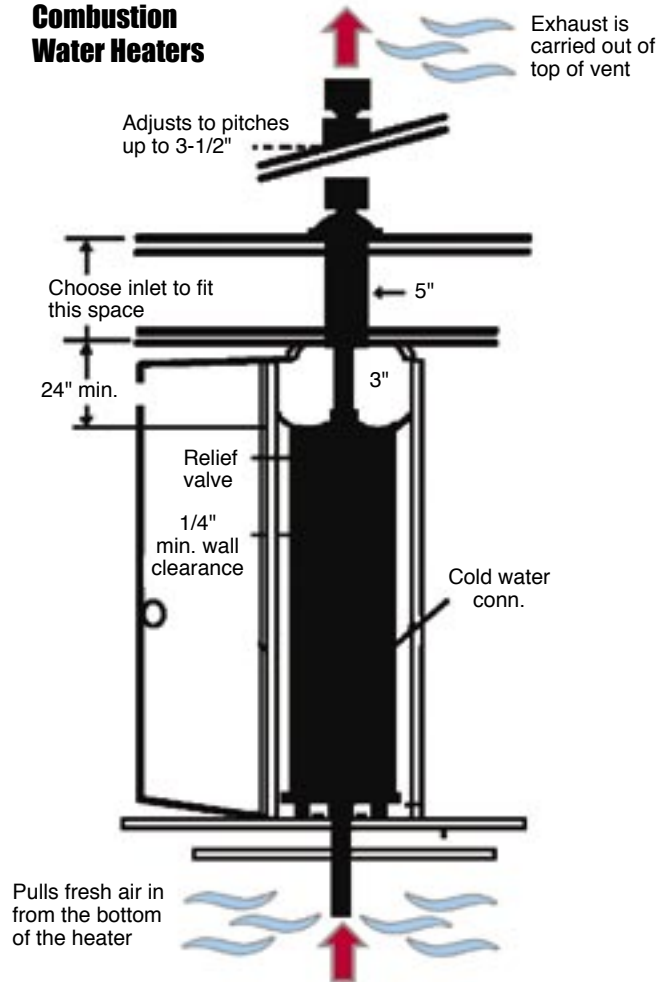

Telescoping Water Heater Gas Stack and Flue Pipe

Overall length: 22-7/8" with flue pipe NOT extended.

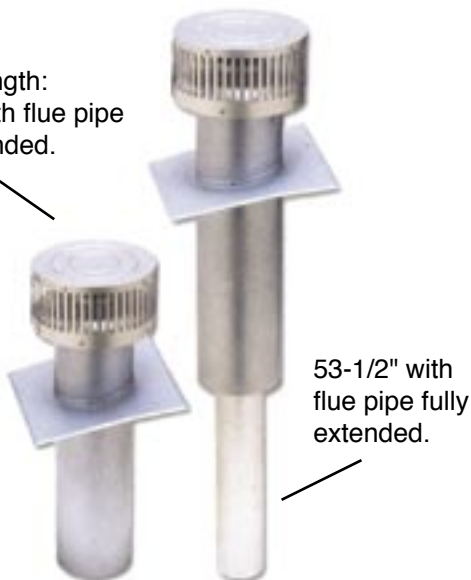

53-1/2" with flue pipe fully extended.

For use with propane gas water heaters. Pulls air from inside of home and vents exhaust out of top of home. Flange has 12° angle for sloped roofs. Extends 8-3/4" above roof line.

- 425195** 4/Ctn.

Each roof jack is packaged with the 11" - 22" adjustable air inlet.



IMPORTANT NOTE:
Roof jack and air inlet must be ordered and installed in accordance to the instructions furnished with the heater. No other roof jack or air inlet assemblies are approved for installation with the heater.

Vent Packages

Includes roof jack and air intake tube.

- 431730** 12" - 15"
- 431731** 24" - 32"
- 431732** 48"
- 431733** Air Intake Kit
- 431734** Roof Jack Ext. Kit 20"
- 237958** Ceiling Ring



Elements

Open Coil Elements



Seven porcelain discs. Stainless steel rod withstands 1300° constant temperature, and the machine-twisted terminal loops insure against burnouts. 50/Ctn.

- 430503** 1500W-120V
- 430504** 2000W-240V
- 430502** 1750W-120V

Universal Adapter Kit

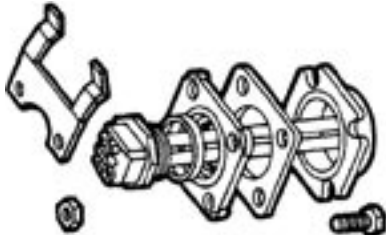

- ▲ 1 each 2-1/2" dia. bolt hole flange
- ▲ 1 each four-hole gasket
- ▲ 1 each 1-5/8" OD x 1-1/8" ID x 2/16" thick gasket
- ▲ 1 each thermostat bracket
- ▲ 4 each 1/2" screws
- ▲ 4 each 3/4" screws with nuts



Converts screw-in element to replace round head, flat flange and universal flange. 12/Ctn.

430604

Screw-In Immersion



1" NPT no-taper screw plug. Fits many models of Rheem, State, Ruud, Norge and others. Includes one gasket.

- 431601** 1500W-120V; 100/Ctn.
- 431602** 4500W-240V; 100/Ctn.
- 431603** 3500W-240V; 100/Ctn.
- 431604** 2000W-120V; 100/Ctn.
- 431600** 1750W-120V; 25/Ctn.
- 431607** 3000W-240V; 12/Ctn.

Square Flange



2-1/2" square, flat surface, 2-1/2" bolt circle, 1-49/64" bolt centers. Includes one gasket. 50/Ctn.

- 430702** 1500W-120V
- 430703** 4500W-240V

Universal Flange



2-1/2" square flange with raised corners. 2-1/2" bolt circle, 1-49/64" bolt centers. Includes one regular "O" ring. 50/Ctn.

- 431201** 1500W-120V
- 431203** 4500W-240V
- 431204** 3500W-240V

Connectors

Flexible Water Connectors



Flexible copper connector for water only.

- 440015** 24"; 25/Ctn.
- 440010** 18"; 25/Ctn.
- 440018** Washer

Flexible Gas Connectors



1/2" OD coated brass tubing 1/2" FPT x 1/2" MPT (tapped 3/8" FPT). Approved for indoor and outdoor use. AGA listed.

- 250815** 18"
- 250816** 24"
- 250817** 36"

PEX Water Heater Swivel Connectors



440017 3/4" insert x 3/4" FPT for PEX tubing & pipe.

Insulation Blanket

Effectively contains the 15% of energy that regularly escapes into the air, saving over 720 kilowatt hours per year. Includes everything you need to insulate your hot water heater. Includes 100" of vinyl tape and instructions. 10/Ctn.

270500



Waterway Connector

For water heater inlet and outlet hookup plus other uses, where dissimilar metals occur in piping and plumbing systems. 3/4" MPT x 3/4" MPT x 3" length MIP. Thermoplastic lining prevents corrosion. Bulk.

431625

